



Operating manual

Permanent Disposal Device

Translation of the
original operating manual
GB

Important!

The operating manual is always to be read before commissioning the equipment. No warranty claim will be granted for faults and damage to the equipment arising from insufficient knowledge of the operating manual.

Copyright

© HORN GmbH & Co. KG. All rights reserved.

Text, graphics and layout copyright protected. Reproduction and copying, including in part, only permitted with written permission. Technical changes reserved.

Service Hotline +49 1805 900 301

(0,14 €/Min: on the German landline network, Mobile telephone max. 0,42 €/Min.)

service@tecalem.it

Document-No.: 44 1595 101-D

As of: 02.07.14

Content

1	Safety instructions.....	3
2	General information	5
	2.1 Appropriate use.....	5
	2.2 Description.....	5
	2.3 Technical data.....	6
	2.4 Dimensional Drawing	7
3	Mounting.....	8
	3.1 Assembly Kit	8
	3.2 Chute elements.....	8
	3.3 Navigable Component.....	9
	3.4 Pump element.....	9
	3.5 Oil extractor electric.....	9
	3.6 Oil extractor pneumatic.....	9
	3.7 Draining by allowing the oil to flow freely.....	10
4	Commissioning.....	10
	4.1 Inspections after assembly	10
	4.2 Power supply	10
5	Operation	10
	5.1 Collecting waste oil	10
6	Maintenance.....	11
	6.1 Telescopic Tube	11
	6.2 Bearing pin.....	11
	6.3 Draining chute	11
	6.4 Pump element.....	11
7	Wiring diagram.....	12
8	Assembly drawing.....	13
	8.1 Assembly drawing system chute.....	13
	8.2 Assembly drawing assembly kit.....	13
	8.3 Assembly drawing pump element.....	14
	8.4 Assembly drawing navigable component.....	14
9	Declaration of Conformity.....	15

1 Safety instructions

The device is a state of the art piece of equipment and has been constructed according to recognised safety specifications. It is nevertheless possible that use of the device will present hazards to the operator or to third parties, or may damage the device or other property. It is therefore essential to act in accordance with these safety instructions, and in particular with those sections identified as warnings.

Warning notices and symbols

In the operating manual, the following signs are used for highlighting important information.



Special information for economical use of the equipment.



Special information or "dos and don'ts" for damage prevention.



Information or "dos and don'ts" for the prevention of damage to persons or equipment.

Appropriate use

- ! The device may only be used if it is in perfect condition, and then only for its intended purpose, in compliance with all safety regulations, with an awareness of the potential risks, and according to the operating manual. Any faults that may impair the safety must be rectified immediately.
-  The device and its components are only to be used for handling the liquids listed and the purpose described. Using the machine for any other purpose would constitute inappropriate use. The manufacturer is not responsible for any loss arising as a result of this, the risk for this is borne only by the operating company.

Organisational measures

- ! This operating manual should always be kept readily available at the site of operation! Each person concerned with the assembly, commissioning, maintenance and operation of the equipment must have read and understood the entire operating manual. It is essential that the type plate and the warning notices attached to the device are observed, and are maintained in a fully readable condition.

Qualified personnel

- ! The operating, maintenance and assembly personnel must be appropriately qualified for their work. The areas of responsibility, competences and supervision of the personnel must be precisely regulated by the operating company. If the personnel do not have the required knowledge, they must be trained and instructed. The operating company must also ensure that the contents of the operating manual are properly understood by the personnel.

Waters protection

-  The device has been designed to handle water hazardous substances. The regulations on the operating place (e.g. Water Resources Act WHG, = ordinance on installations for handling of substances hazardous to water VAWS) must be adhered to.

Maintenance and Service

-  According to the regulations of the water resources law only authorized services may work on devices for flammable and/or water endangering substances. During such works, appropriate tools are to be used (avoid sparking). Before any kind of work on the device, all fuel lines are to be completely emptied and aerated. Do not make any changes. Modifications or additions to the device which may affect the safety cannot be carried out without consent of the manufacturer. Exclusively genuine spare parts made by the manufacturer may be used.

Electric power

-  Work on the electrical equipment may only be carried out by a qualified electrician or by trained persons under the guidance and supervision of a qualified electrician according to electro-technical guidelines. Machine or system components, on which inspection, maintenance or repair work is to be carried out must be de-energised.

Hydraulics

-  Only persons with special knowledge and experience with hydraulic systems may carry out work on hydraulic parts and equipment. All lines, hoses and screw joints should regularly be checked for leaks and visible external damage. Any damage must be rectified immediately. Any oil spurting out can cause injuries and fire. The relevant safety regulations for the product must be followed when handling oils, greases or other chemical substances!

Compressed air

-  Only persons with special knowledge and experience with pneumatic systems may carry out work on pneumatic parts and equipment. Prior to any inspection, maintenance or repair work, ensure that the equipment is not under pressure. All lines, hoses and screw joints should regularly be checked for leaks and external damage. Any damage must be rectified immediately.

2 General information

2.1 Appropriate use

The Permanent Disposal Device is a system for catching and transporting used lubricating oil from motor vehicle engines to an on-site waste oil storage tank.

! The system chute and the temporary tank in the pump element are not intended for the storage of liquids. The Permanent Disposal Device should only be used with fully functional conveying and drainage equipment.

It is intended for use in industry, workshops, service stations and similar establishments and was designed especially for use in motor vehicle workshop pits.

⚠ The Permanent Disposal Device should not be operated with inflammable and potentially explosive liquids with a flash point below 55°C. Fluids with a flash point above 55°C may not be transported if these are heated beyond their flash point. Use in potentially explosive areas is not permitted. In such cases there is a danger of explosion!

2.2 Description

Draining chute with navigable component

The chute system has been envisaged especially for long truck pits. Due to the compact construction, the system can be optimally mounted under the pit rim. The rail system integrated into the draining chute assures the easy navigation of the firm navigable component. The cantilever arm of the twofold telescopic collecting tub is mounted on the turn able joint of the navigable component, and can be folded in to save space. Opening guard plates on the collecting tub and a sieve keep the workplace clean. Large, free profiles in the telescopic pipe and the cantilever arm ensure the rapid drainage of used oil.

The accompanying assembly kit includes all pieces necessary for the mounting of the draining chute. The components necessary for wall mounting are also included, with exception of the material necessary for mounting onto the pit walls (screws, dowels). The sealing material for the connection of the draining chutes respectively the cover lid is included in the components supply.

Optional Components

According to the specific requirements on site, optional components can be added onto the chute system.

An adjustable pump element with temporary tank and level control absorbs the fluid from the chute system and conveys it into the tank system. The pump element can be used with an electric or a pneumatic conveyor pump. The level control ensures the activation and deactivation of the conveyor pump and controls a signal lamp which lights up when there is danger of overfilling the chute system.

When using a conveyor pump, the end of the chute system is habitually covered with blind flanges.

Alternatively, it is possible to drain the system chute by allowing the oil to flow freely into an attached collecting tub. To do so, a finishing cap with a 2" connection should be fitted to the connector on the piping.

To avoid the pollution of the chute system, a special, retrofit able rubber seal can be fitted into it.

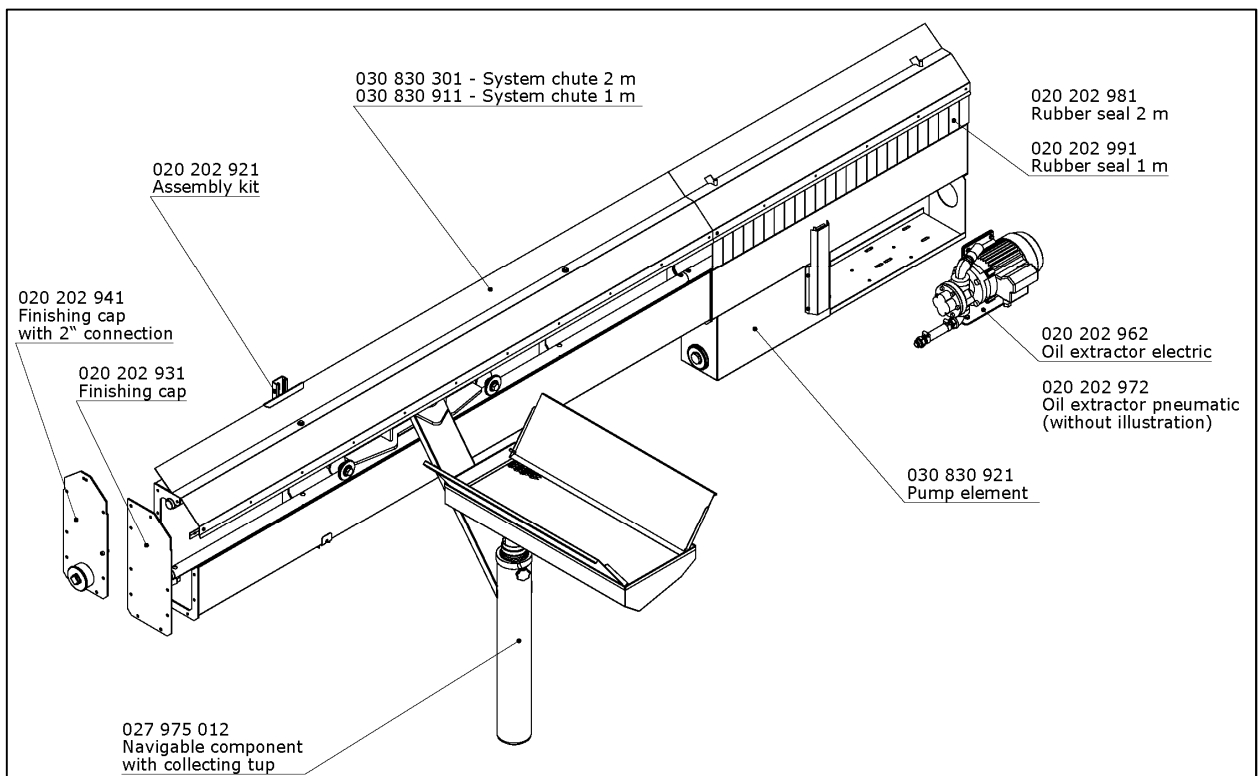

2.3 Technical data

Systemchute

Length	1 m / 2 m
Volume	approx. 16 Litres / m

Pumpelement

Volume temporary tank	approx. 13 Litres
Level at switch point	min approx. 4 Litres
	max approx. 11 Litres
	max/max approx. 15 Litres in pump element

Fahrwagen mit Auffangwanne

Height adjustability	approx. 800 mm
Dim. collecting tub	700 x 280 mm
max. swivelradius	approx. 1400 mm
Volume collecting tub	approx. 15,5 Litres

Oil extractor electric

Driving power	Electrical three-phase motor
Pump type	Externally toothed gearwheel pump
Power consumption	0.37 kW
Power supply	3/N/PE AC 50Hz 400V

Rated current: 1.1 A
Nominal flow volume 10 litres per minute
Nominal pump pressure 10 bar
Oil pressure hose 950 mm, G3/4" external thread

Oil extractor pneumatic

Pump type Pneumatic double membrane pump
Transmission 1 : 1
Max. air input pressure 7 bar
Max. pump pressure 7 bar
Max. flow volume 19 litres per minute
Max. air consumption 250 litres per minute
Oil pressure hose 950 mm, G3/4" external thread
Air supply hose 1000 mm, outer diameter 8 mm

General

Viscosity range 5000 mm² per second
Ambient temperature 0° up to +40°
Oil temperature 0° up to +55°

2.4 Dimensional Drawing

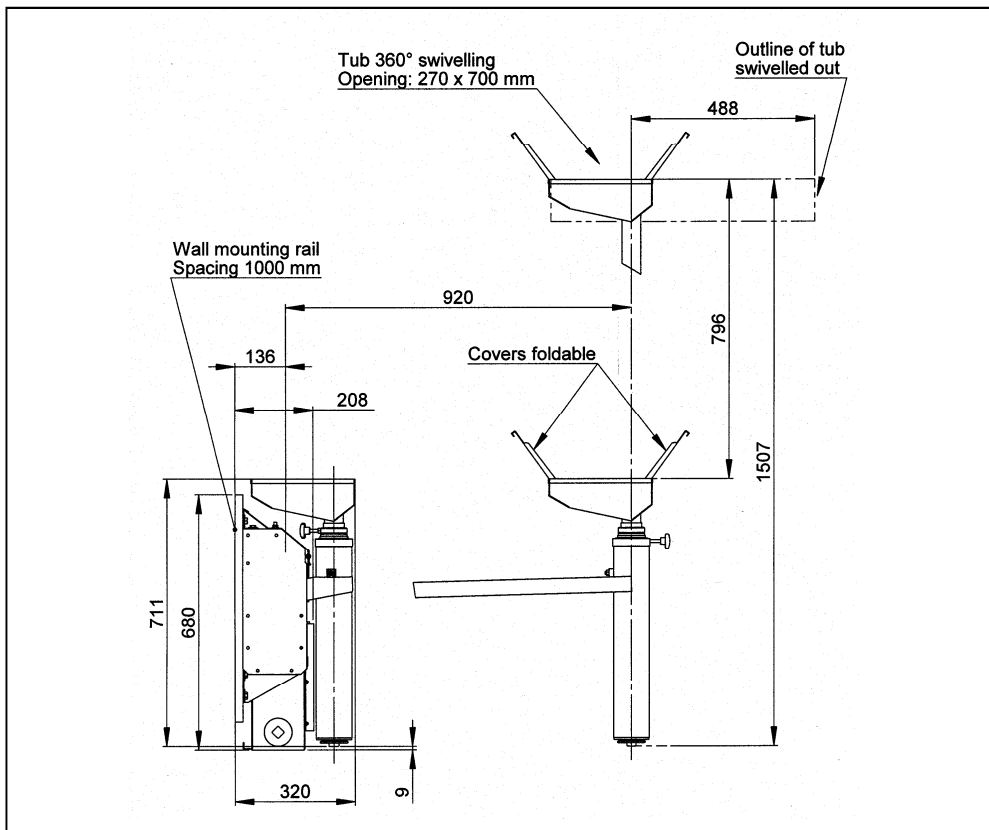

3 Mounting

Before beginning the mounting, the positions of both chute ends are to be marked, and the distances to the pit rim and pit base are to be checked.

The draining chute should be laid with a down gradient of approx. 1cm over a length of 20 m. The pump element or the draining flange is to be installed at the deepest point.



Please follow the indications on the mounting diagrams.

3.1 Assembly Kit

The C-rails of the assembly kit are mounted with 1 m spacing. Hereto mount the first rail vertically aligned at 0,5 m distance from the chute end and at least 50 mm under the pit rim. With a guideline position the last rail accordingly distanced to the chute elements to be mounted.

Example:

Total length of chutes: $5 \times 2 \text{ m elements} + 1 \times 1 \text{ m element} = 11 \text{ m}$

Distance between first and last C - rail: $11 \text{ m} - (2 \times 0,5 \text{ m}) = 10 \text{ m}$

The remaining C-rails are now mounted onto the pit wall spaced by 1 meter, following the guideline. Premount the bearing cantilevers of the assembly kit with the guideline according to the gradient of the chute system.

3.2 Chute elements

Mount the chute elements and a possible pump element starting out from a chute end. Hereto lay the element onto the lower cantilever and position with the upper retaining bracket. Put the flat gasket onto the chute flange and stick the connection sleeves into the guiding pipe. Now position the next chute element and screw flanges together.

After complete mounting of all elements, and inspection of correct alignment, throw over the plates standing over the bearing cantilevers with a hammer (use plastic hammer!) and fix the upper retaining brackets definitively.

The finishing flanges are to be screwed against the chute end with the sealing compound. Please follow the indications concerning the processing of the sealing compound.



Only connect the finishing caps to the system chute once the vehicle is in place.

After the complete mounting of all chute elements, the covers can be assembled and connected to the plates. The free space on the pit wall can be used to lay cables or similar.

3.3 Navigable Component

Firstly, the collecting tub is to be mounted onto the navigable component. Hereto grease the swivel bolt well and fix into the bearing buck of the navigable component with the safety ring.

Initial mounting

After the first chute elements are mounted, the navigable component can be slid onto the rails from an open chute end.

Inserting into a completely mounted chute system

Dismantle the four wheels. Lift the base plate with mounted collecting tub into a chute element without a cover. Guide the base plate behind the rails, lay the wheels on the rails and assemble. For the dismantling, proceed reversely.

3.4 Pump element

The pump element and the desired extraction unit are pre-assembled in the factory.

Connection to the waste oil pipe

Affix the flexible pipe that is attached to the connected pipework to the waste oil storage tank.



**In each instance, a non-return valve should be applied to the pressure line
All connections should be oiltight and pressure resistant.**

Electrical connection

The electrical connection of the pump and controls should only be carried out by a qualified electrician in accordance with the wiring diagram.



Mount the supplied signal light where it can be clearly seen.

3.5 Oil extractor electric

The assembly is pre-mounted in the pump element.

Delivery contents: electrical delivery pump, suction hose, a flexible metal pipe for connecting to the pressure line, the controls and a signal light.



Before putting into operation, check the rotational direction of the engine and the conveying direction of the pump.

3.6 Oil extractor pneumatic

The assembly is pre-mounted in the pump element.

Delivery contents: pneumatic delivery pump, suction hose, a flexible metal pipe for connecting to the pressure line, maintenance and shutoff units for fitting to the compressed air supply, the controls and a signal light.

3.7 Draining by allowing the oil to flow freely

To allow the oil to drain freely through the finishing cap, a pipe with 2" nominal diameter should be fitted to the on-site waste oil tank. Ensure that its incline is sufficient. The pipe joint is to be applied at the lower end of the system chute.

4 Commissioning

4.1 Inspections after assembly

Take into consideration the setting time of the sealant used to seal the finishing caps. Before use, the equipment should again be checked for correct functioning (conveyor unit, telescopic collecting tub) and complete, oiltight assembly (finishing caps, draining flanges, pump connections).

4.2 Power supply

Before use, switch on the power supply with the motor protection switch in the control housing.



Switch off power supply if the equipment will not be used for a longer period.

5 Operation

The Permanent Disposal Device is intended solely for the disposal of engine oil and gear oil of known origin.



Operation with oil of unknown origin, solvents, fuels, brake fluids, cooling liquids etc. is not permitted.

The thereby collected mixture in the used oil tank cannot be reprocessed as old oil, and has to be disposed of adequately. Ensure that the collected oil is not polluted by rubbish and the like thrown into the chute system.

During breaks, the navigable component is to be swung under the pit rim, in parking position, with closed telescopic tube and folded guard plates.

The navigable compound is constructed to be able to carry the normal workload and additional loads that may arise; nevertheless avoid unnecessary loading.



Persons standing on the lateral pipe, and laying down heavy loads onto the construction will cause straining on the construction and wearing of the components, especially of the bearings.

5.1 Collecting waste oil

To empty oil from a motor vehicle's engine, position the vehicle under the oil drain plug. Loosen the clamps on the navigable component and set the collecting tub to the desired height. Re-secure the locking screws. Before opening the drain plug on the engine, ensure that the guard plates on the collecting tub are open.

The following rules should be observed:



The volume of oil introduced should not exceed the system volume (temporary tank and system chute)!

The speed at which oil is introduced should not notably exceed the pump's flow volume!

An overflow indicator warns when the filling level is too high. The oil feed should then be immediately halted and the cause of the problem resolved.

6 Maintenance

The Permanent Disposal Device is a system for dealing with liquids that are hazardous to water.



The operator should take the appropriate precautions to ensure safe usage.

In particular, the oil-bearing components and the conveying system should be examined regularly to ensure proper functioning and that there are no leaks or damage.

Do not use a system that has faults!

6.1 Telescopic Tube

Rinse the telescopic system with an adequate cleansing fluid (e.g. diesel). Place a collecting tub under the tube and remove the lower cap during cleansing.

If the telescopic tube is very dirty, dismantle it. Remove the slug above the lateral pipe, the inner tubes can now be pulled out. The oil from the telescopic tubes remains in the riser pipe and does not need to be drained.

6.2 Bearing pin

The bearing pin should be relubricated with suitable bearing grease at least once a month. Use the lubricating nipple fitted to the vehicle's bearing box for this purpose.

6.3 Draining chute

Large impurities, such as objects or rubbish thrown into the draining chute, can hinder the drainage of the oil, or even block the chute. Check and clean the dirt trap in the pump element or draining pipe at least once a week.

6.4 Pump element



The functioning of the three level switches, the signal lamp and the conveyor pump is to be checked regularly.

This can be done by manually activating the level switches. Here to remove the dirt trap.

7 Wiring diagram

The following circuit diagram shows the wiring of the controls with the electrical pump, the level switches and the overfill safety device of the on-site waste oil tank. When using a pneumatic pump, a 230 V AC connection is enough to drive the compressed air shut-off valve.

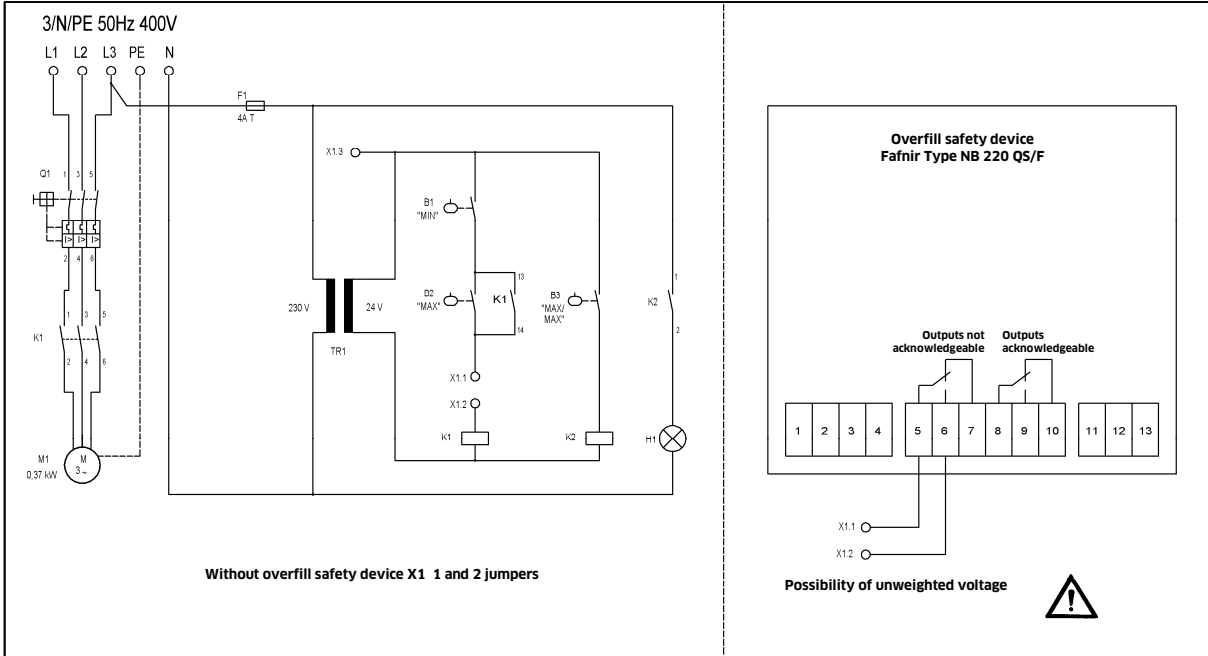

020202962

Oil extractor electric

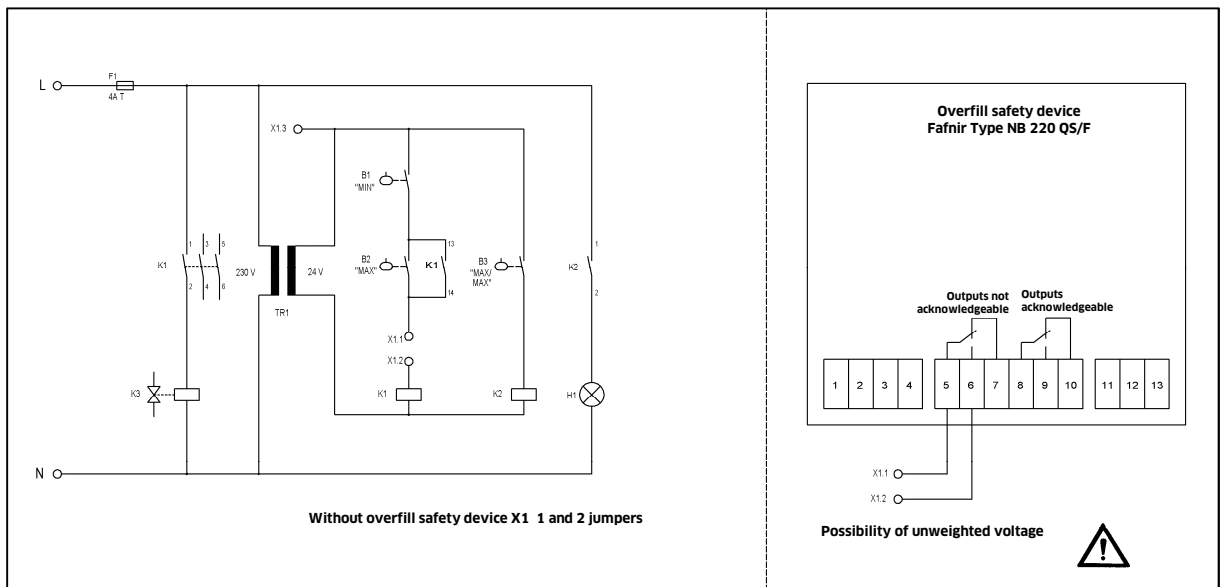

020202972

Oil extractor pneumatic

8 Assembly drawing

8.1 Assembly drawing system chute

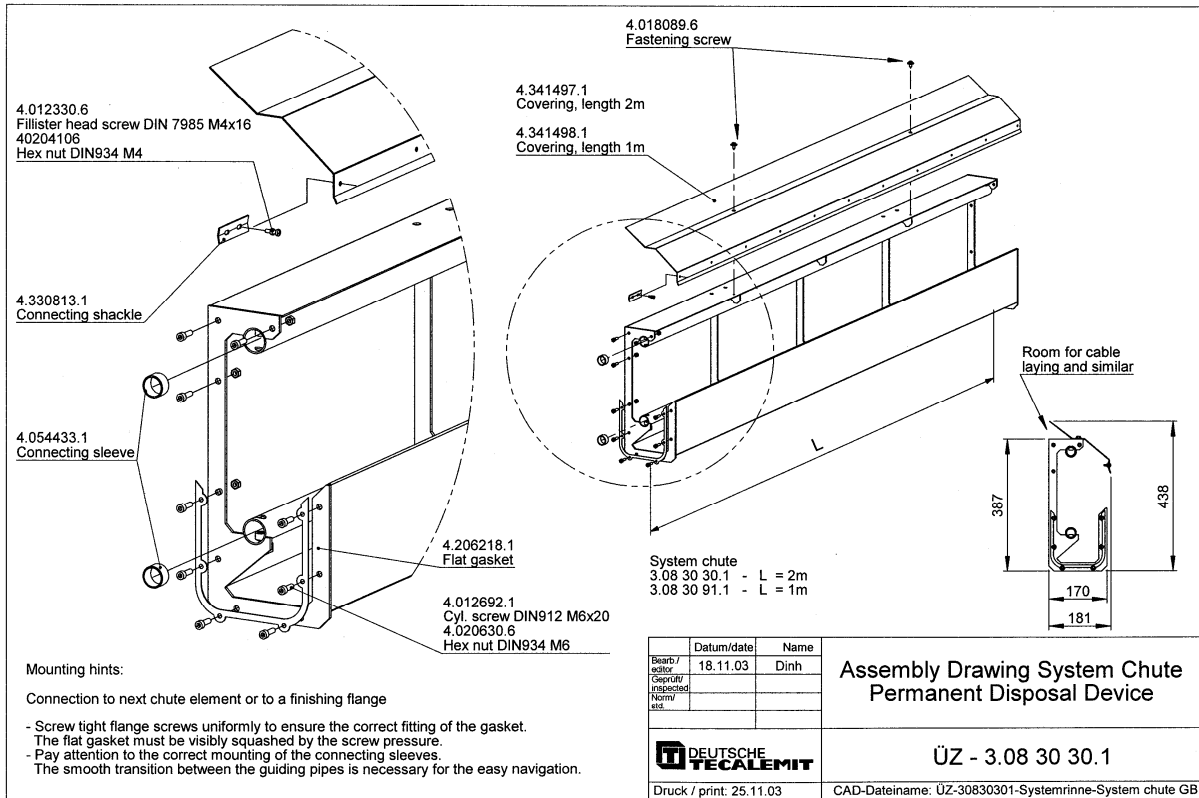

8.2 Assembly drawing assembly kit

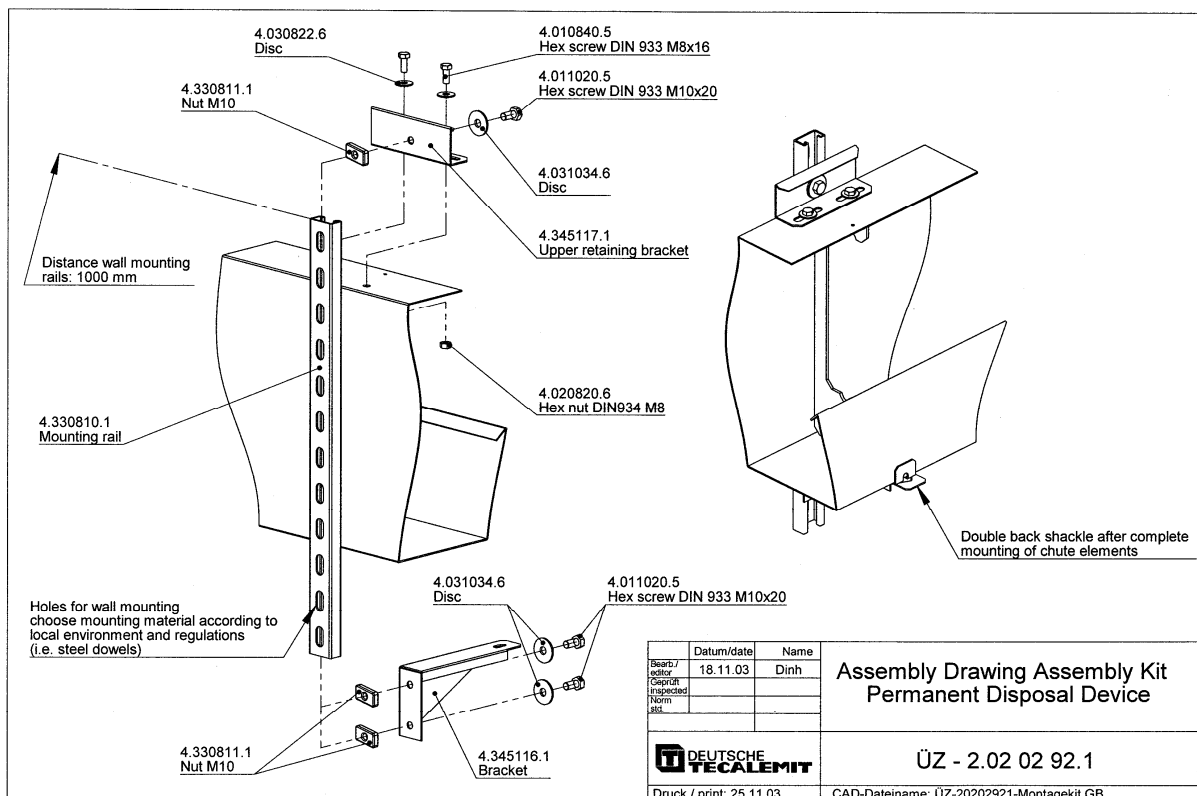

8.3 Assembly drawing pump element

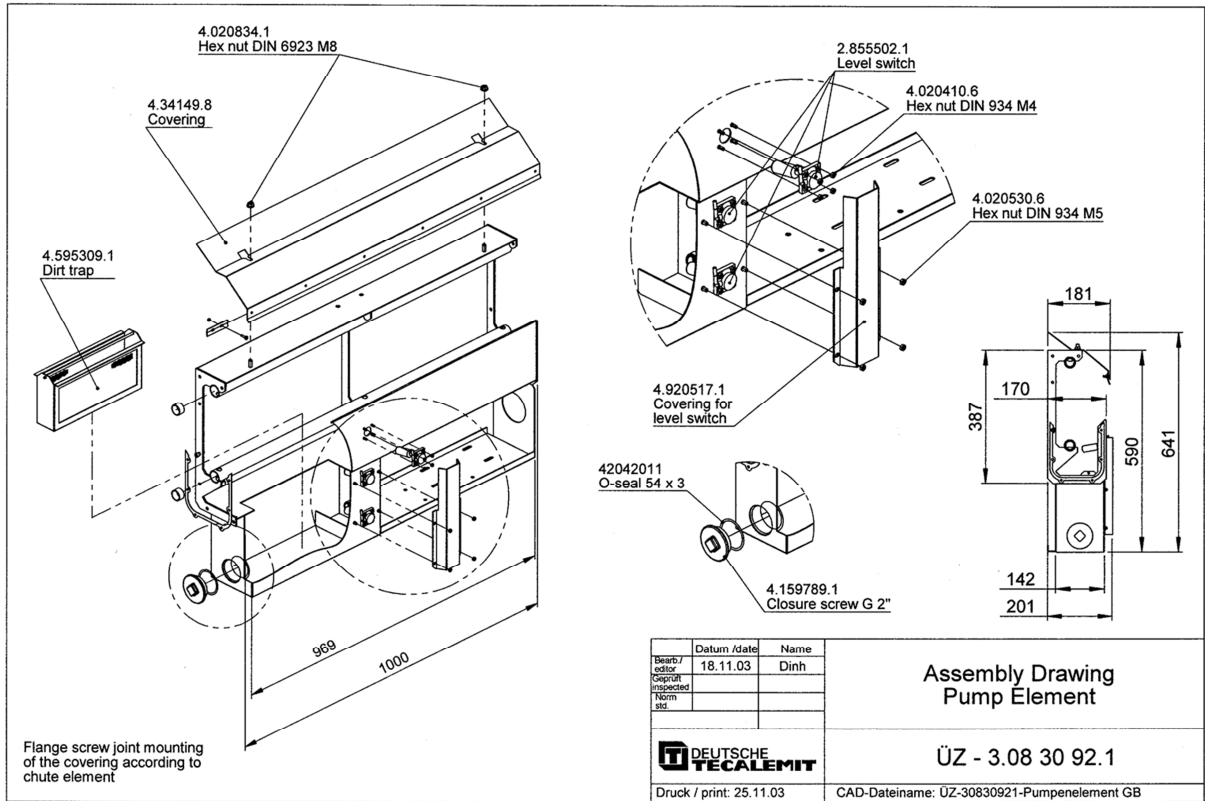

8.4 Assembly drawing navigable component

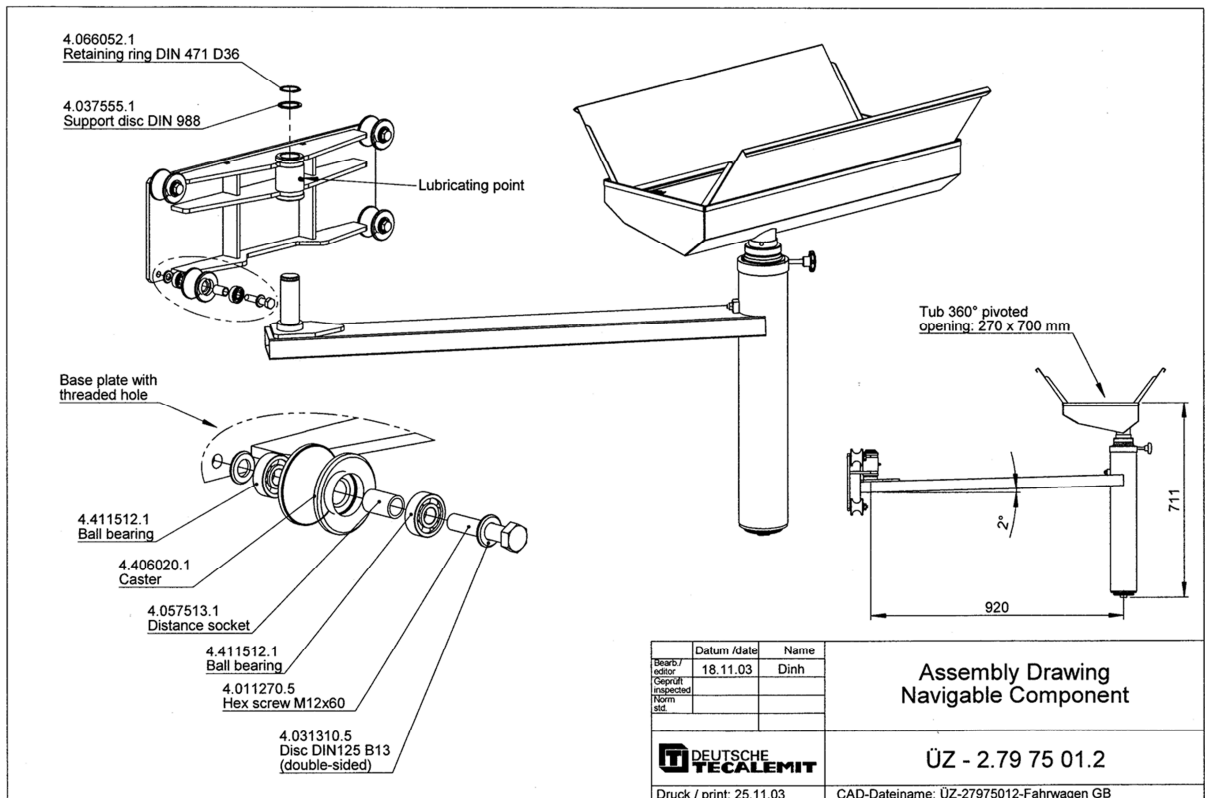



Konformitätserklärung Declaration of Conformity

Hiermit erklären wir, dass die Bauart
We herewith declare that the construction type

Typ: <i>Type:</i>	Bausatz Ölabsauger el./pneum. Oil suction kit el./pneum.
Bezeichnung: <i>Designation:</i>	Ölförderaggregat Oil delivering device
Artikel-Nr.: <i>Item No.:</i>	020202962, 020202972

in der von uns gelieferten Ausführung folgenden einschlägigen Bestimmungen entspricht:
in the form as delivered by us complies with the following applicable regulations:

- | | |
|---|--|
| - Maschinenrichtlinie 2006/42/EG
<i>Machinery directive 2006/42/EC</i> | - EMV-Richtlinie 2004/108/EG
<i>EMC directive 2004/108/EC</i> |
|---|--|

Angewendete harmonisierte Normen:
Applied harmonised standards:

DIN EN ISO 12100 DIN EN 809

EG-Dokumentationsbevollmächtigter: <i>EC official agent for documentation:</i>	Jörg Mohr	Horn GmbH & Co. KG Munketoft 42 24937 Flensburg
---	-----------	---

23.05.2013
*Datum
Date*



 i.V. Dipl.-Ing. Jörg Mohr
 Entwicklungsleiter / *Engineering Manager*

HORN GmbH & Co. KG
Munketoft 42
D-24937 Flensburg
Germany

T +49 461 8696-0
F +49 461 8696-66
info@tecalem.it.de
www.tecalem.it.de

Geschäftsführer:
Torsten H. Kutschinski

Commerzbank AG
BLZ 215 400 60
Konto-Nr. 2476000

SWIFT COBADEFFXXX
IBAN DE33215400600247600000
Amtsgericht Flensburg HRA 4264
UST-IdNr. DE813038919

Horn GmbH & Co. KG
Munketoft 42
24937 Flensburg
Germany

T +49 461-8696-0
F +49 461-8696-66

www.tecalemit.de
info@tecalemit.de